

I2C Protocol

Mitesh Khadgi

For queries, contact: mitesh.khadgi2025@gmail.com

Introduction

- I2C combines the best features of SPI and UARTs. With I2C, you can connect multiple slaves to a single master (like SPI) and you can have multiple masters controlling single, or multiple slaves. This is really useful when you want to have more than one microcontroller logging data to a single memory card or displaying text to a single LCD.
- Like UART communication, I2C only uses two wires to transmit data between devices

Signals in I2C Protocol

- **SDA (Serial Data)** – The line for the master and slave to send and receive data.
- **SCL (Serial Clock)** – The line that carries the clock signal

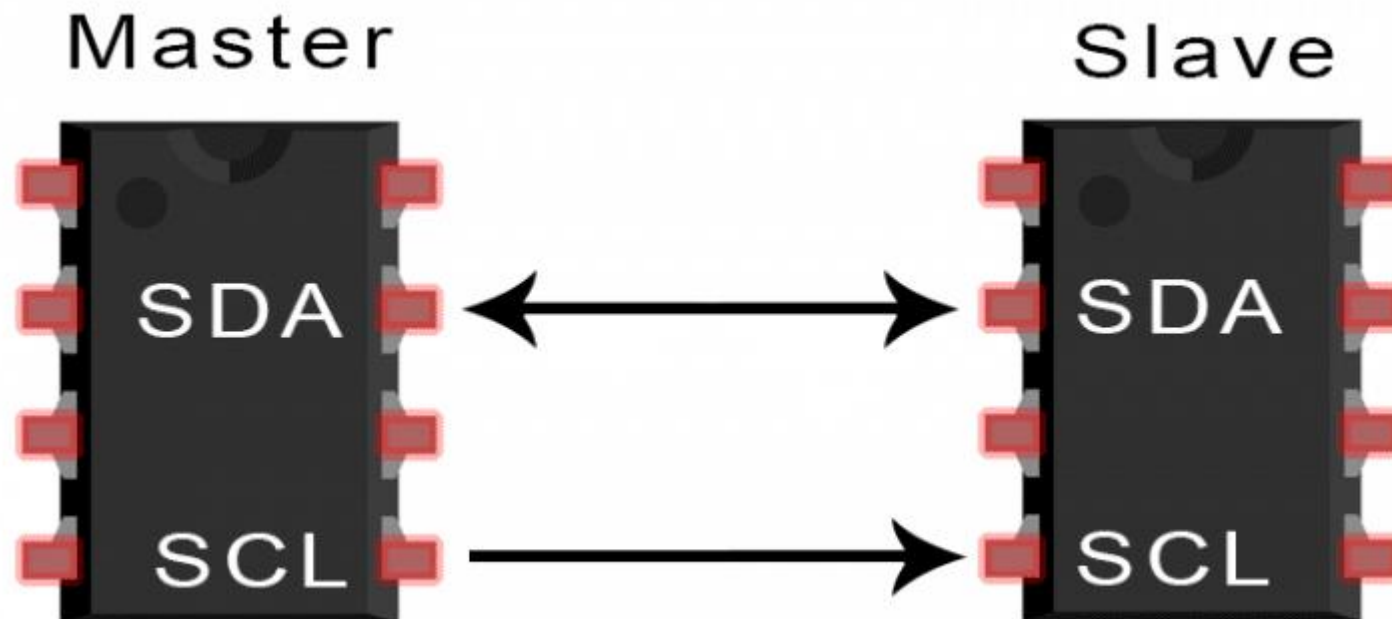

Definition

- I2C is a serial communication protocol, so data is transferred bit by bit along a single wire (the SDA line).
- Like SPI, I2C is synchronous, so the output of bits is synchronized to the sampling of bits by a clock signal shared between the master and the slave. The clock signal is always controlled by the master.

Properties of I2C Protocol

Wires Used	2
Maximum Speed	Standard mode= 100 kbps Fast mode= 400 kbps High speed mode= 3.4 Mbps Ultra fast mode= 5 Mbps
Synchronous or Asynchronous?	Synchronous
Serial or Parallel?	Serial
Max # of Masters	Unlimited
Max # of Slaves	1008

How it works?

- With I2C, data is transferred in *messages*. Messages are broken up into *frames* of data. Each message has an address frame that contains the binary address of the slave, and one or more data frames that contain the data being transmitted. The message also includes start and stop conditions, read/write bits, and ACK/NACK bits between each data frame:

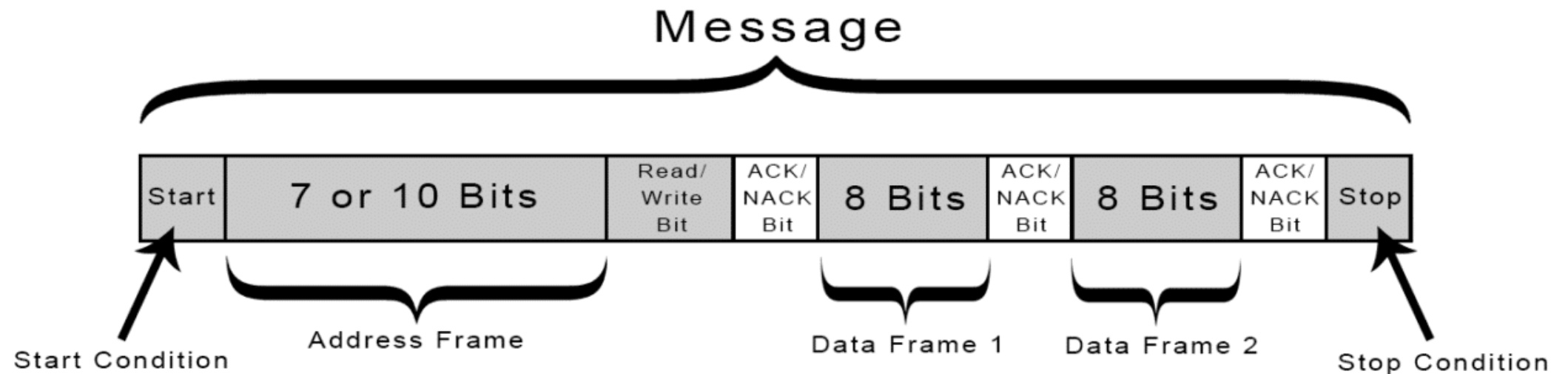

Start and Stop Conditions

- **Start Condition:** The SDA line switches from a high voltage level to a low voltage level *before* the SCL line switches from high to low.
- **Stop Condition:** The SDA line switches from a low voltage level to a high voltage level *after* the SCL line switches from low to high.
- **Address Frame:** A 7 or 10 bit sequence unique to each slave that identifies the slave when the master wants to talk to it.
- **Read/Write Bit:** A single bit specifying whether the master is sending data to the slave (low voltage level) or requesting data from it (high voltage level).
- **ACK/NACK Bit:** Each frame in a message is followed by an acknowledge/no-acknowledge bit. If an address frame or data frame was successfully received, an ACK bit is returned to the sender from the receiving device.

Addressing

- I2C doesn't have slave select lines like SPI, so it needs another way to let the slave know that data is being sent to it, and not another slave. It does this by *addressing*. The address frame is always the first frame after the start bit in a new message.
- The master sends the address of the slave it wants to communicate with to every slave connected to it. Each slave then compares the address sent from the master to its own address. If the address matches, it sends a low voltage ACK bit back to the master. If the address doesn't match, the slave does nothing and the SDA line remains high.

READ/WRITE BIT

- The address frame includes a single bit at the end that informs the slave whether the master wants to write data to it or receive data from it. If the master wants to send data to the slave, the read/write bit is a low voltage level. If the master is requesting data from the slave, the bit is a high voltage level.

THE DATA FRAME

- After the master detects the ACK bit from the slave, the first data frame is ready to be sent.
- The data frame is always 8 bits long, and sent with the most significant bit first. Each data frame is immediately followed by an ACK/NACK bit to verify that the frame has been received successfully. The ACK bit must be received by either the master or the slave (depending on who is sending the data) before the next data frame can be sent.
- After all of the data frames have been sent, the master can send a stop condition to the slave to halt the transmission. The stop condition is a voltage transition from low to high on the SDA line after a low to high transition on the SCL line, with the SCL line remaining high.

Steps of I2C Data Transmission

- 1. The master sends the start condition to every connected slave by switching the SDA line from a high voltage level to a low voltage level *before* switching the SCL line from high to low:

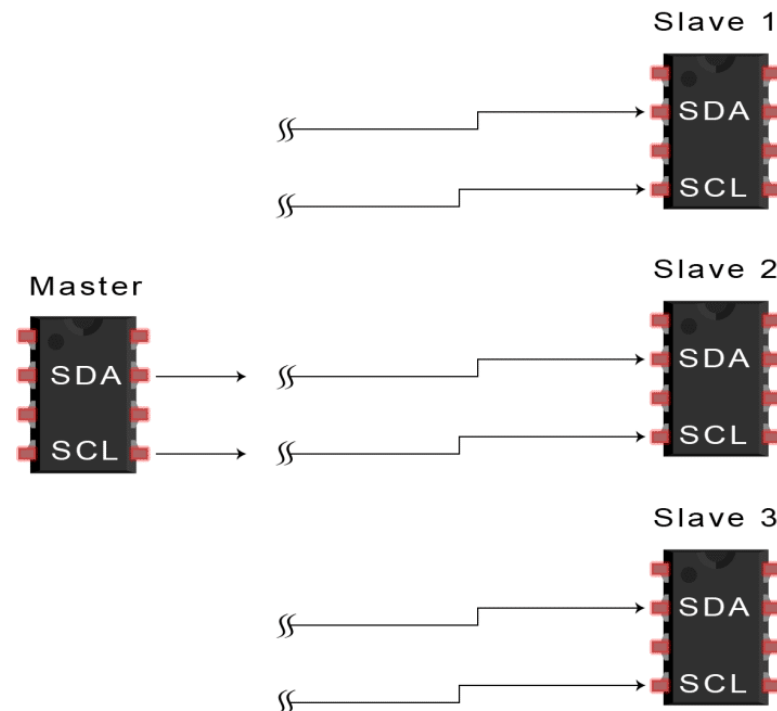

Steps of I2C Data Transmission

- 2. The master sends each slave the 7 or 10 bit address of the slave it wants to communicate with, along with the read/write bit:

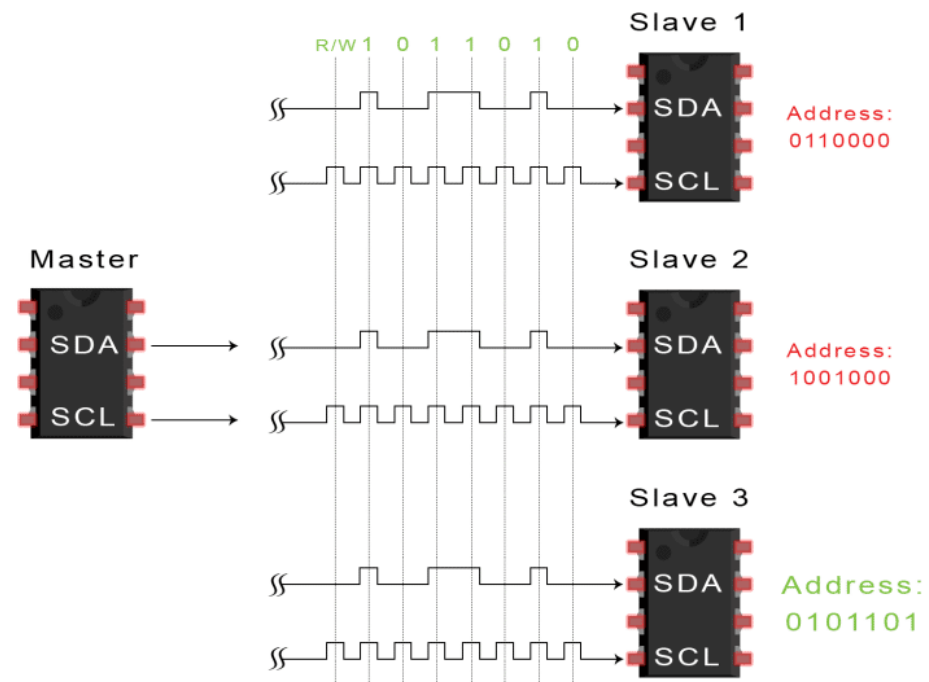

Steps of I2C Data Transmission

- 3. Each slave compares the address sent from the master to its own address. If the address matches, the slave returns an ACK bit by pulling the SDA line low for one bit. If the address from the master does not match the slave's own address, the slave leaves the SDA line high.

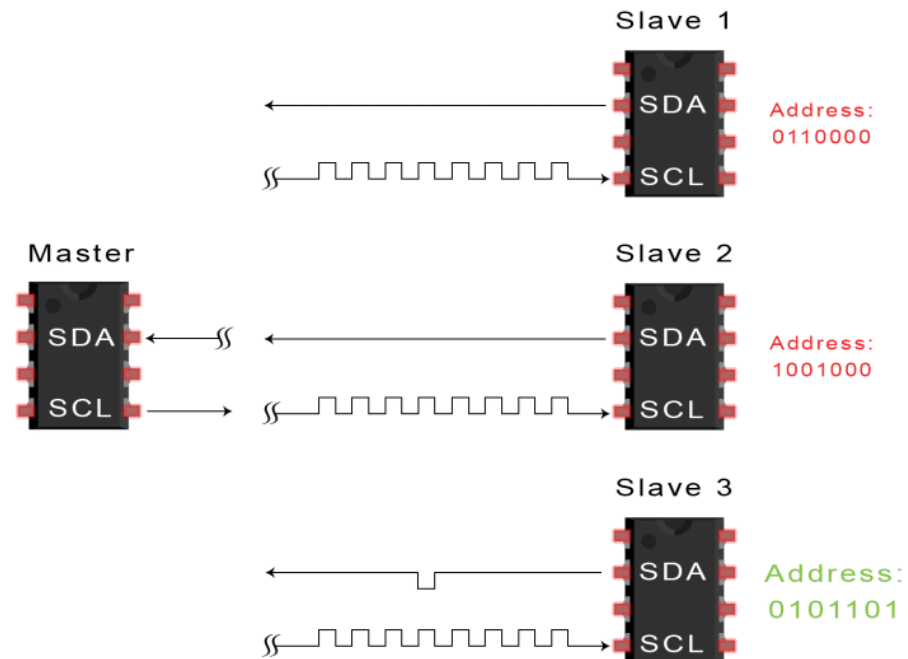

Steps of I2C Data Transmission

- 4. The master sends or receives the data frame:

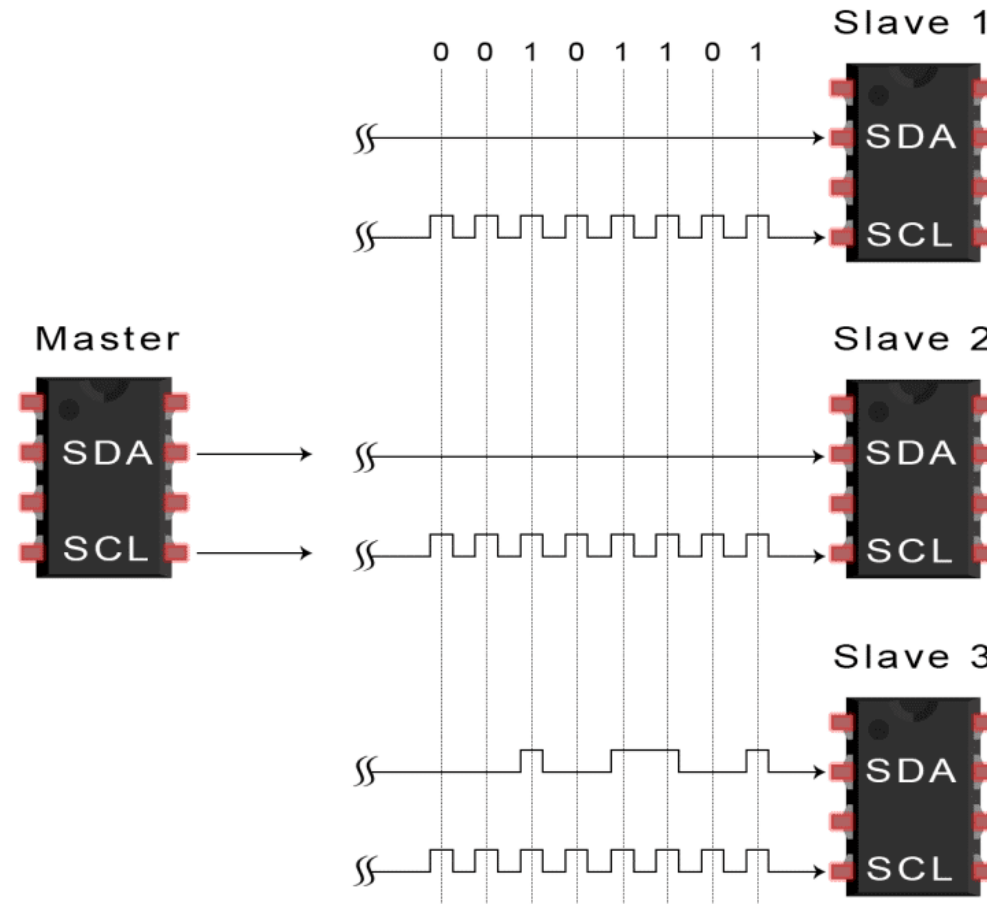

Steps of I2C Data Transmission

- 5. After each data frame has been transferred, the receiving device returns another ACK bit to the sender to acknowledge successful receipt of the frame:

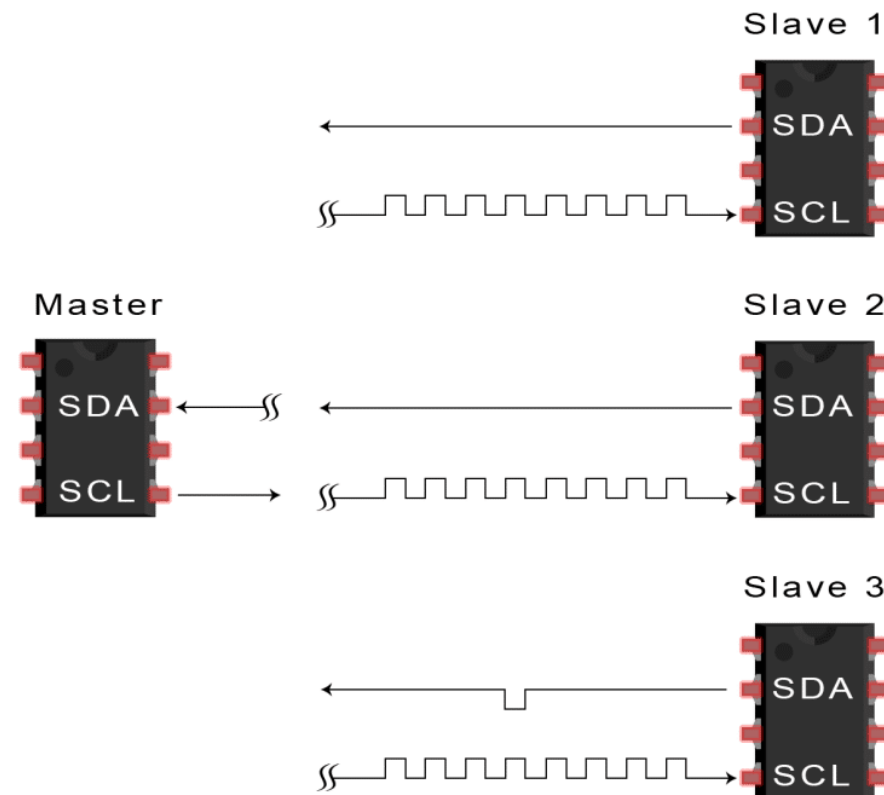

Steps of I2C Data Transmission

- 6. To stop the data transmission, the master sends a stop condition to the slave by switching SCL high before switching SDA high:

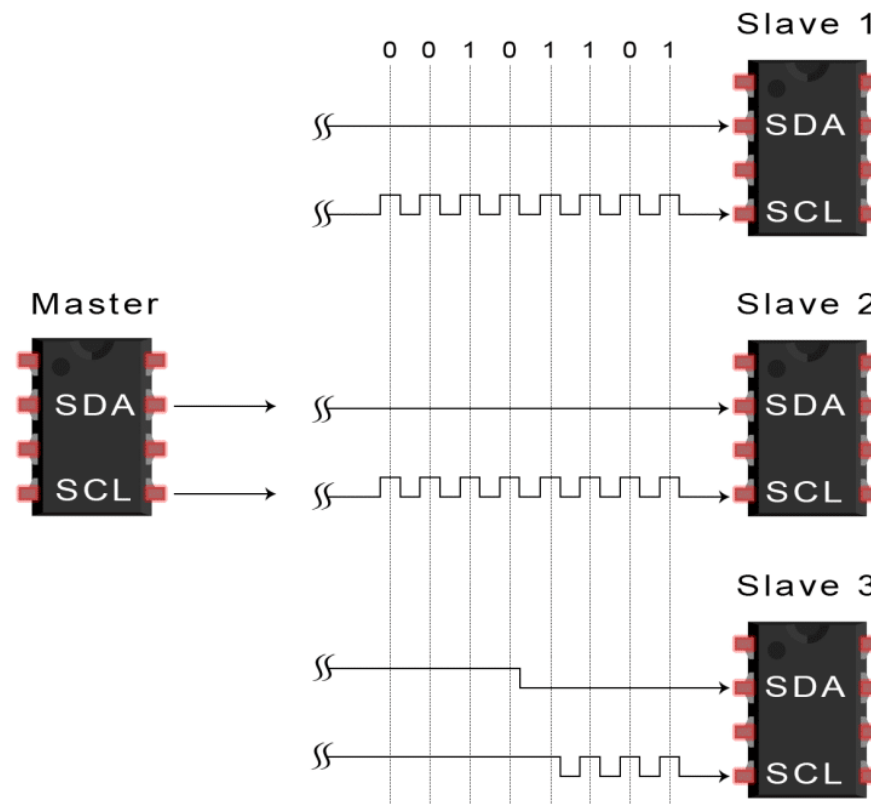

Single Master with Multiple Slaves

- Because I2C uses addressing, multiple slaves can be controlled from a single master. With a 7 bit address, 128 (2^7) unique address are available. Using 10 bit addresses is uncommon, but provides 1,024 (2^{10}) unique addresses. To connect multiple slaves to a single master, wire them like this, with 4.7K Ohm pull-up resistors connecting the SDA and SCL lines to Vcc:

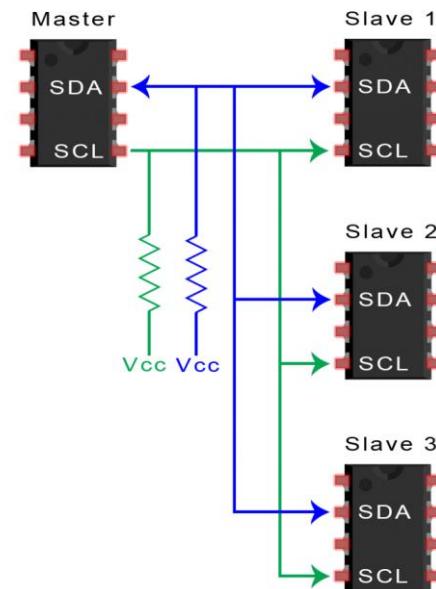

Multiple Masters with Multiple Slaves

- Multiple masters can be connected to a single slave or multiple slaves. The problem with multiple masters in the same system comes when two masters try to send or receive data at the same time over the SDA line. To solve this problem, each master needs to detect if the SDA line is low or high before transmitting a message. If the SDA line is low, this means that another master has control of the bus, and the master should wait to send the message. If the SDA line is high, then it's safe to transmit the message. To connect multiple masters to multiple slaves, use the following diagram, with 4.7K Ohm pull-up resistors connecting the SDA and SCL lines to Vcc:

Multiple Masters with Multiple Slaves

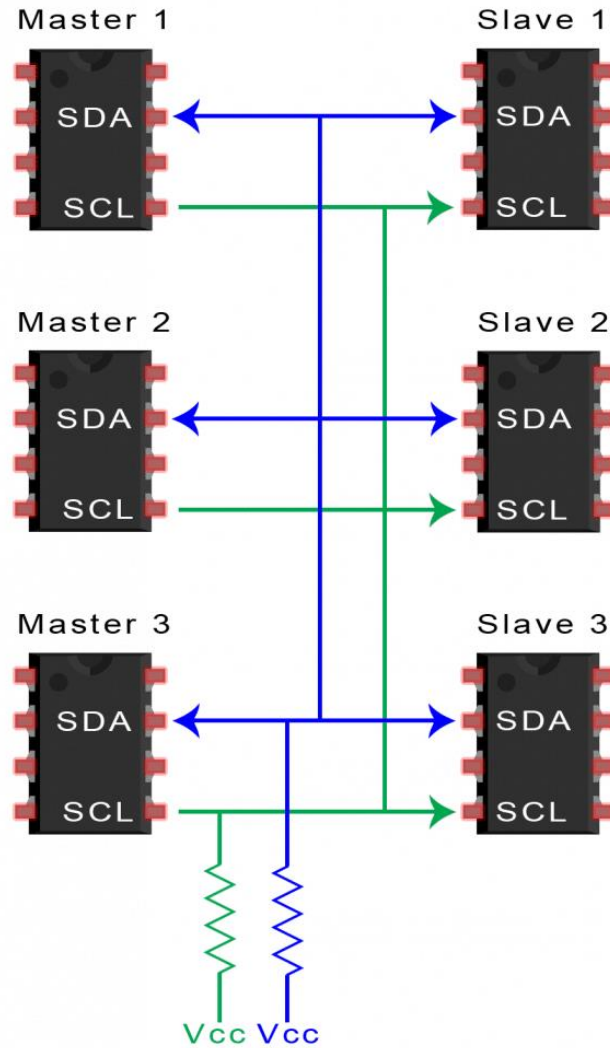

Advantages and Disadvantages of I2C Protocol

- There is a lot to I2C that might make it sound complicated compared to other protocols, but there are some good reasons why you may or may not want to use I2C to connect to a particular device:

Advantages

- Only uses two wires
- Supports multiple masters and multiple slaves
- ACK/NACK bit gives confirmation that each frame is transferred successfully
- Hardware is less complicated than with UARTs
- Well known and widely used protocol

Disadvantages

- Slower data transfer rate than SPI
- The size of the data frame is limited to 8 bits
- More complicated hardware needed to implement than SPI

Thank You 😊